

mimSAFE

www.mimsafe.com

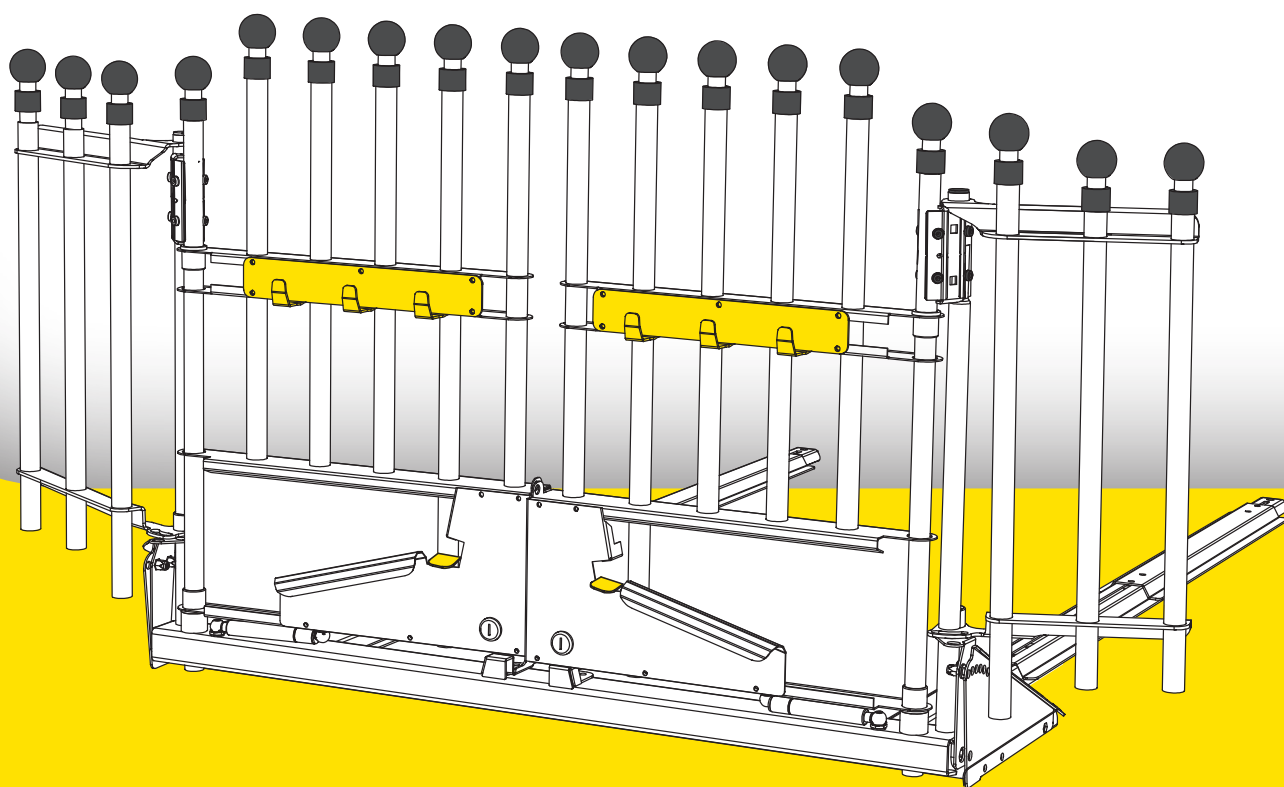

ASSEMBLY INSTRUCTIONS

VARIOGATE

double



IMPORTANT

GENERAL

VarioGate is made to create an enclosed area of the entire luggage compartment that can be used for transport of dogs or anything else you want to keep protected. VarioGate is adjustable in terms of height, width and depth, making it suitable for most cars without a threshold in the rear.

The VarioGate is made of splinter proof and energy absorbing materials. It has undergone rigorous crash tests. It's design-protected and made of galvanized steel painted with a very weather-resistant polyurethane paint suitable for its use. The doors are equipped with a gas spring that keeps the door open when needed.

BEFORE YOU BEGIN

Ensure that you work on a flat surface. If the VarioGate is assembled indoors, protect the floor with a blanket or carpet to avoid damage during assembly. Read the instruction carefully before you begin, it gives you a better understanding when you work step by step during the assembly. You can assemble the VarioGate by yourself, but it helps a lot to be two during some of the assembly steps.

RECOMMENDED AREA OF USE

VarioGate should be installed in the luggage compartment of the car.

CRASH TEST

This model is crash tested at **Rise Research Institutes of Sweden AB** Frontal Impact test of a VarioGate according to ECE Regulation No. 17

Test protocol is available from the manufacturer on request.

DAILY INSPECTION

- Make sure the VarioGate is intact
- That there's no sharp edges
- That the door lock works
- Check the straps and that it is attached to the vehicle's cargo loops

CLEANING

Use a soft cloth with water and mild soap.

The story of MIMsafe

For more than 30 years, MIMsafe has worked with functional design and manufacturing of safety products for the modern automotive industry. With documentation from hundreds of crash tests and in close collaboration with the major car manufacturers, safe products have been developed and transformed into knowledge. Under the well-known brand name MIMsafe, we have become the leading manufacturer of crash tested and crush proofed non-whiplash dog cages all over the world.

MANUFACTURER

MIM Construction AB
Myren 125
SE-462 94 Frändefors
Sweden

+46 10 55 00 450
info@mim.se
www.mimsafe.com

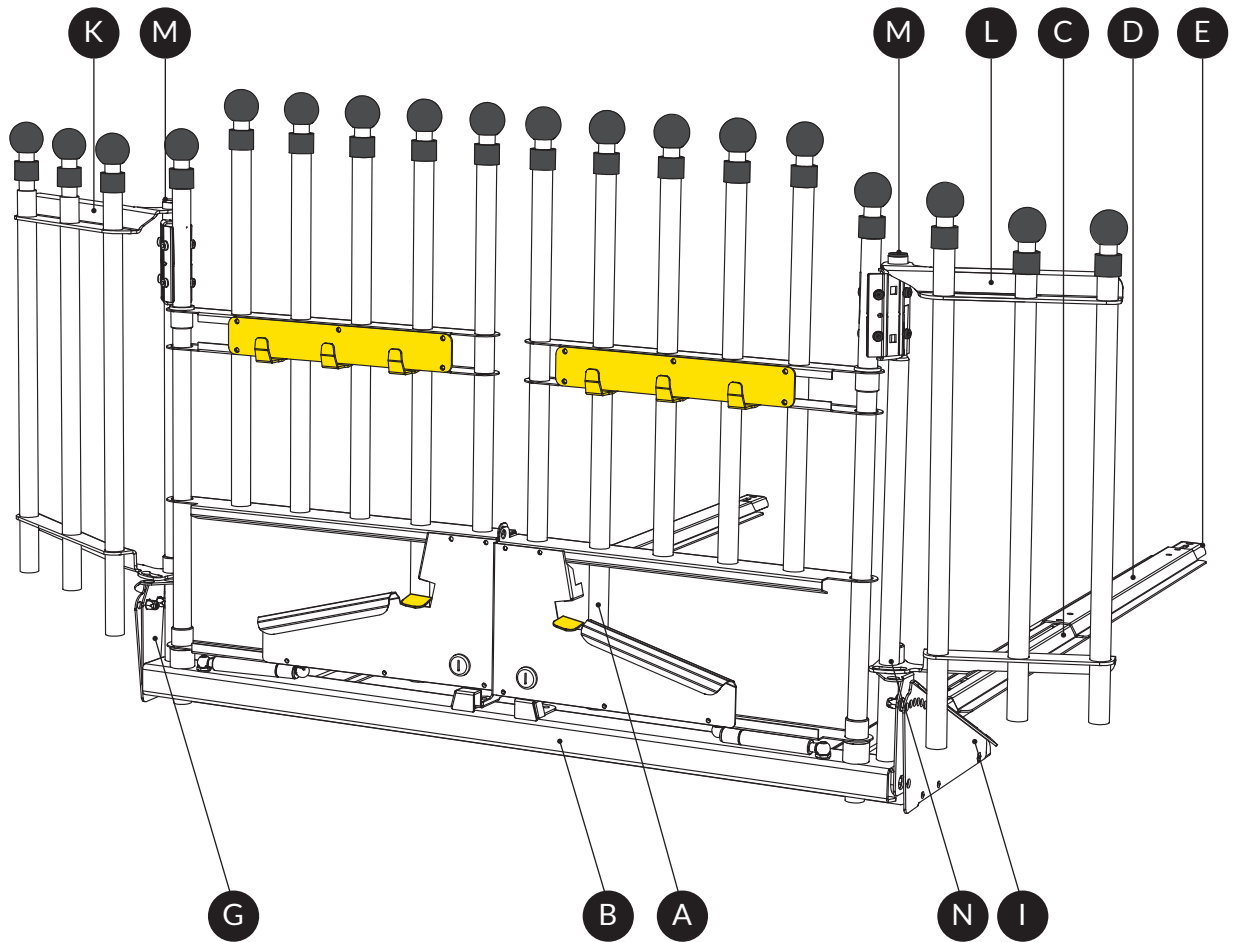

BAG #1 Product no. 00285-MS-1

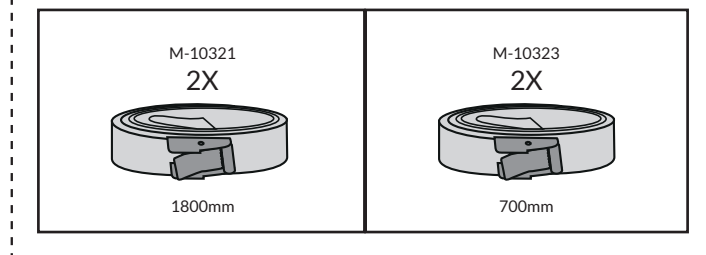

BAG #2 Product no. 53252-MS-2

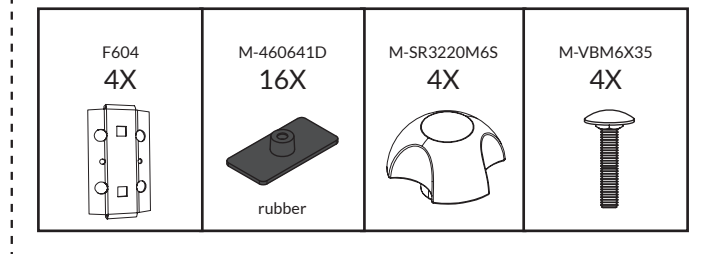

BAG #3 Product no. 53252-MS-3

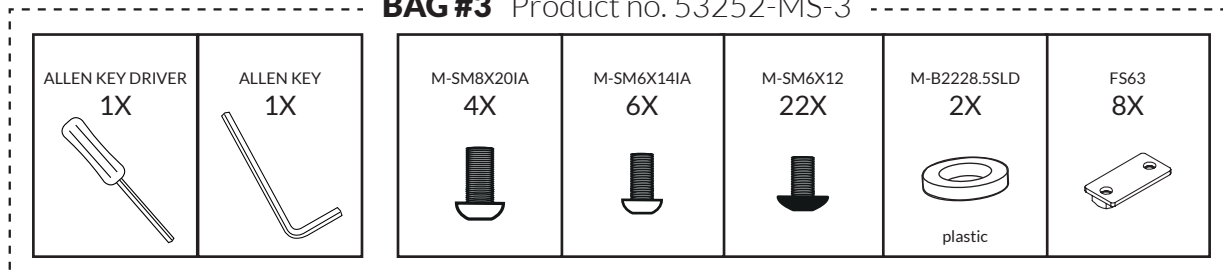

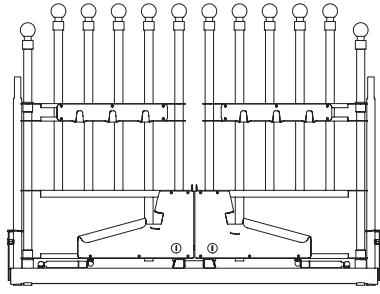

A Door section

FS605A	1X
Art.no	No of items

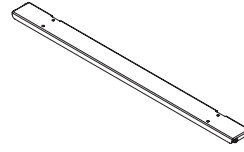

B Floor plate

F299B	1X
Art.no	No of items



G Left angle plate

F337L	1X
Art.no	No of items

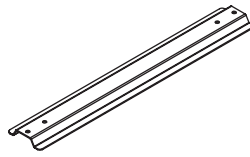

C Foot plate #1

F336	2X
Art.no	No of items

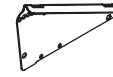

I Right angle plate

F337R	1X
Art.no	No of items

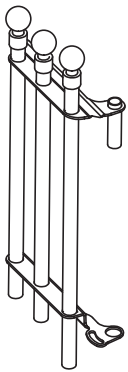

K Left wing

FS603-3	1X
Art.no	No of items

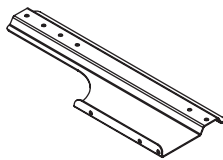

H Left foot

F337AL	1X
Art.no	No of items

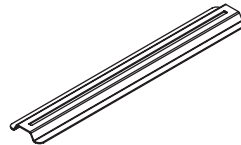

D Foot plate #2

F336A	2X
Art.no	No of items

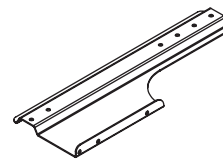

J Right foot

F337AR	1X
Art.no	No of items

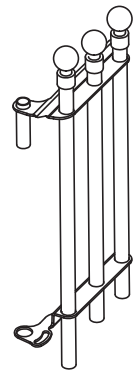

L Right wing

FS604-3	1X
Art.no	No of items



E Foot plate #3

F336B	2X
Art.no	No of items

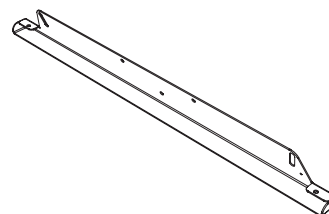



O Front floor plate

F530	1X
Art.no	No of items

STEP
1

2X

M-SM6X12 8X	FS63 4X
	

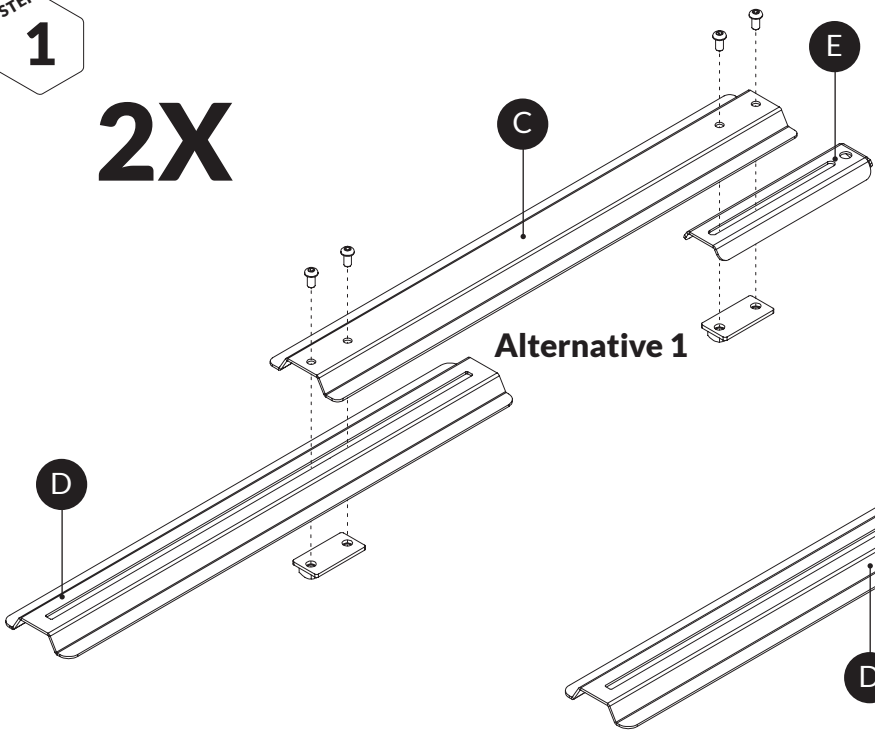

Alternative 1

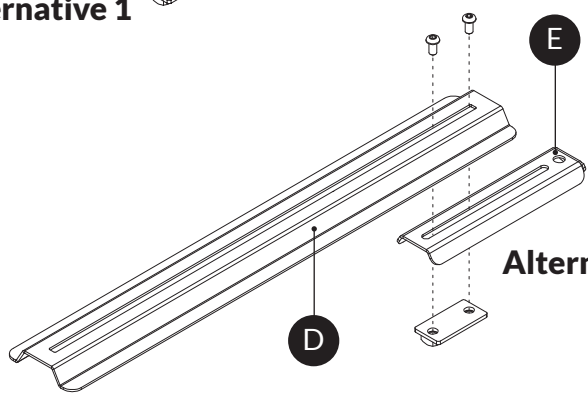

Alternative 2

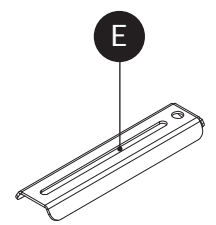

Alternative 3





IMPORTANT!

The parts C and D are optional depending on the depth of your car's trunk



DEPTH BY POSSIBLE COMBINATIONS		
PARTS	MIN. DEPTH	MAX. DEPTH
D+C+E	1060mm	1500mm
D+E	670mm	1050mm
E	550mm	620mm

STEP
2

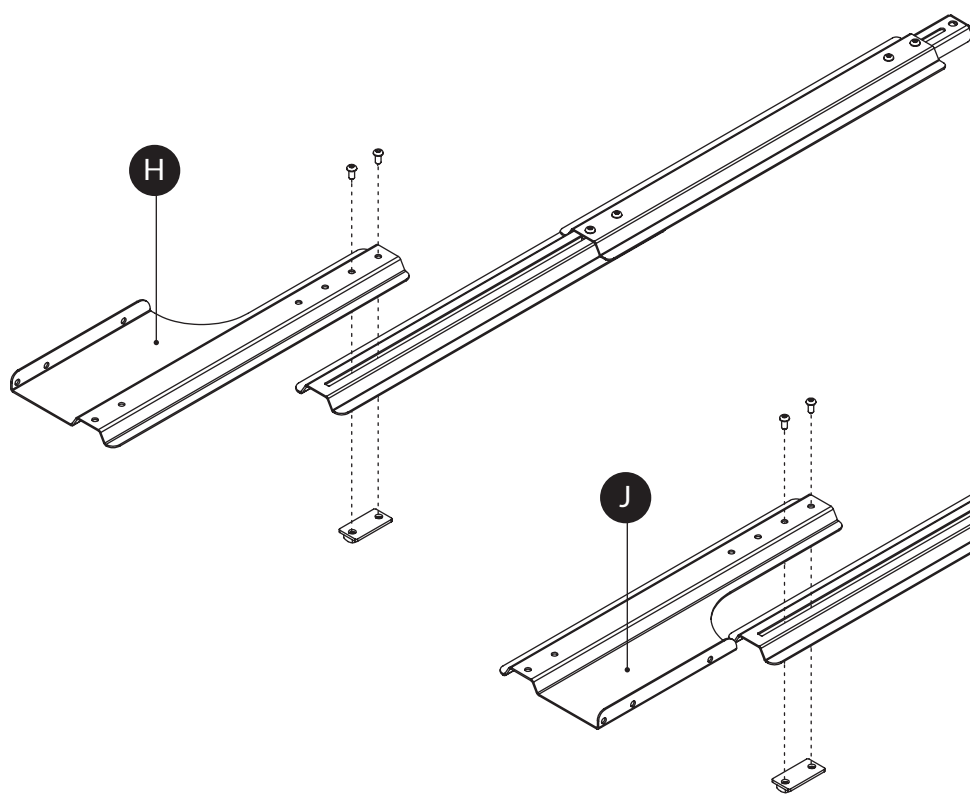
FS63 2X	M-SM6X12 4X
	



STEP
3

FS63 2X	M-SM6X12 4X
	

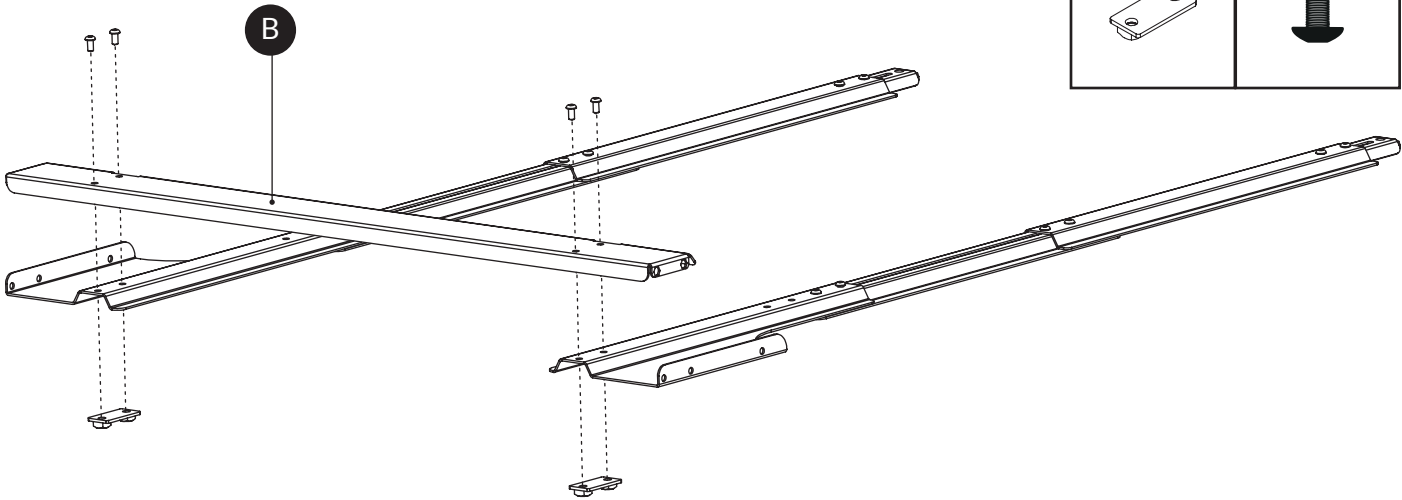

STEP
4

M-SM6X14IA 4X

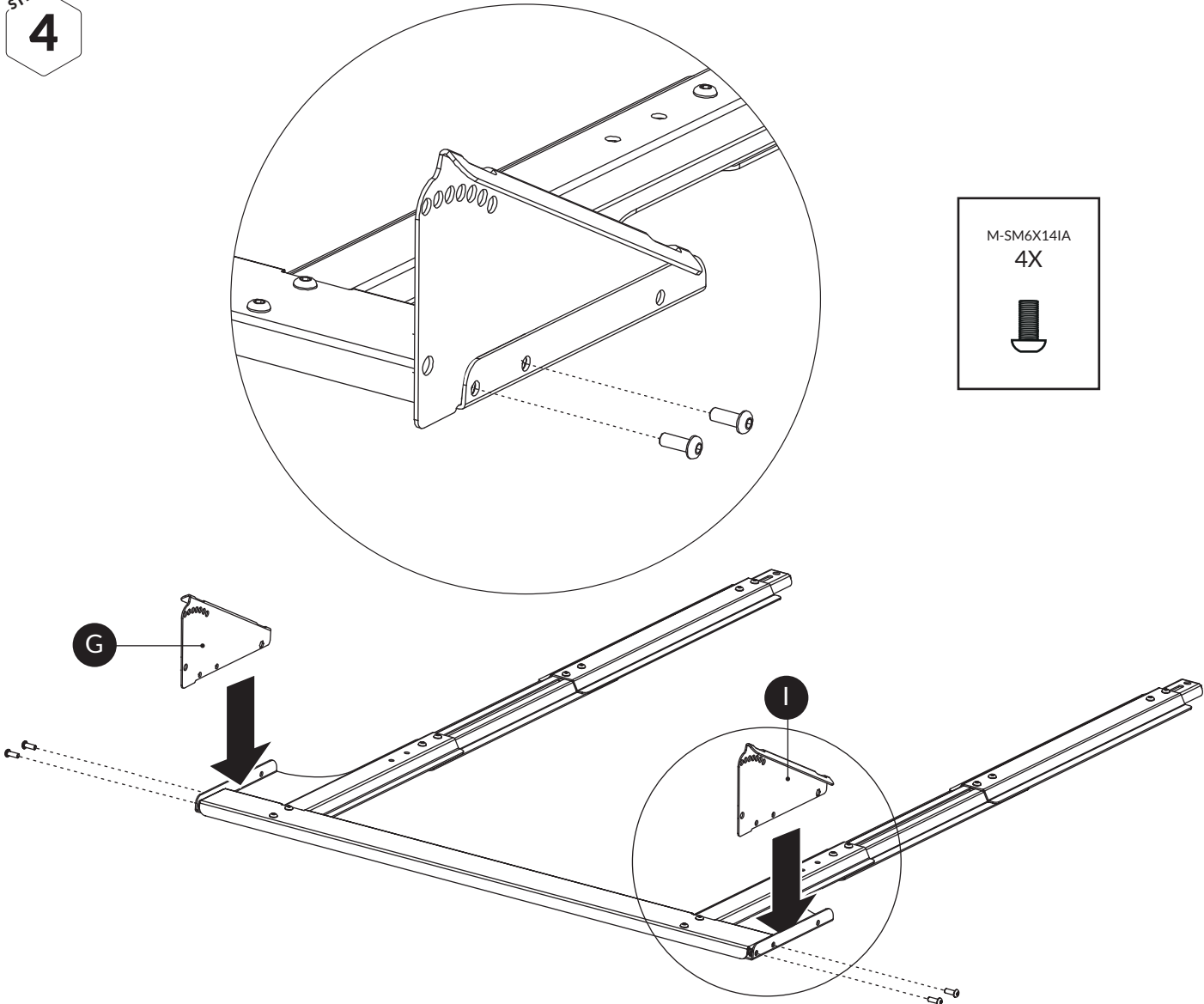

STEP
5

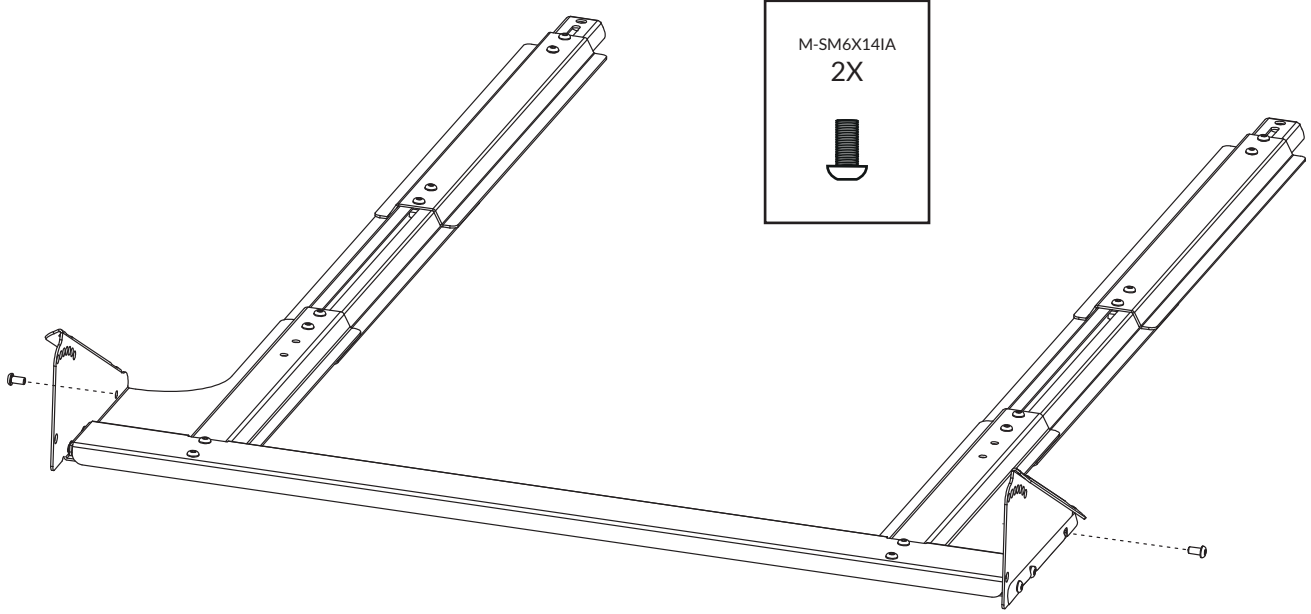

STEP
6

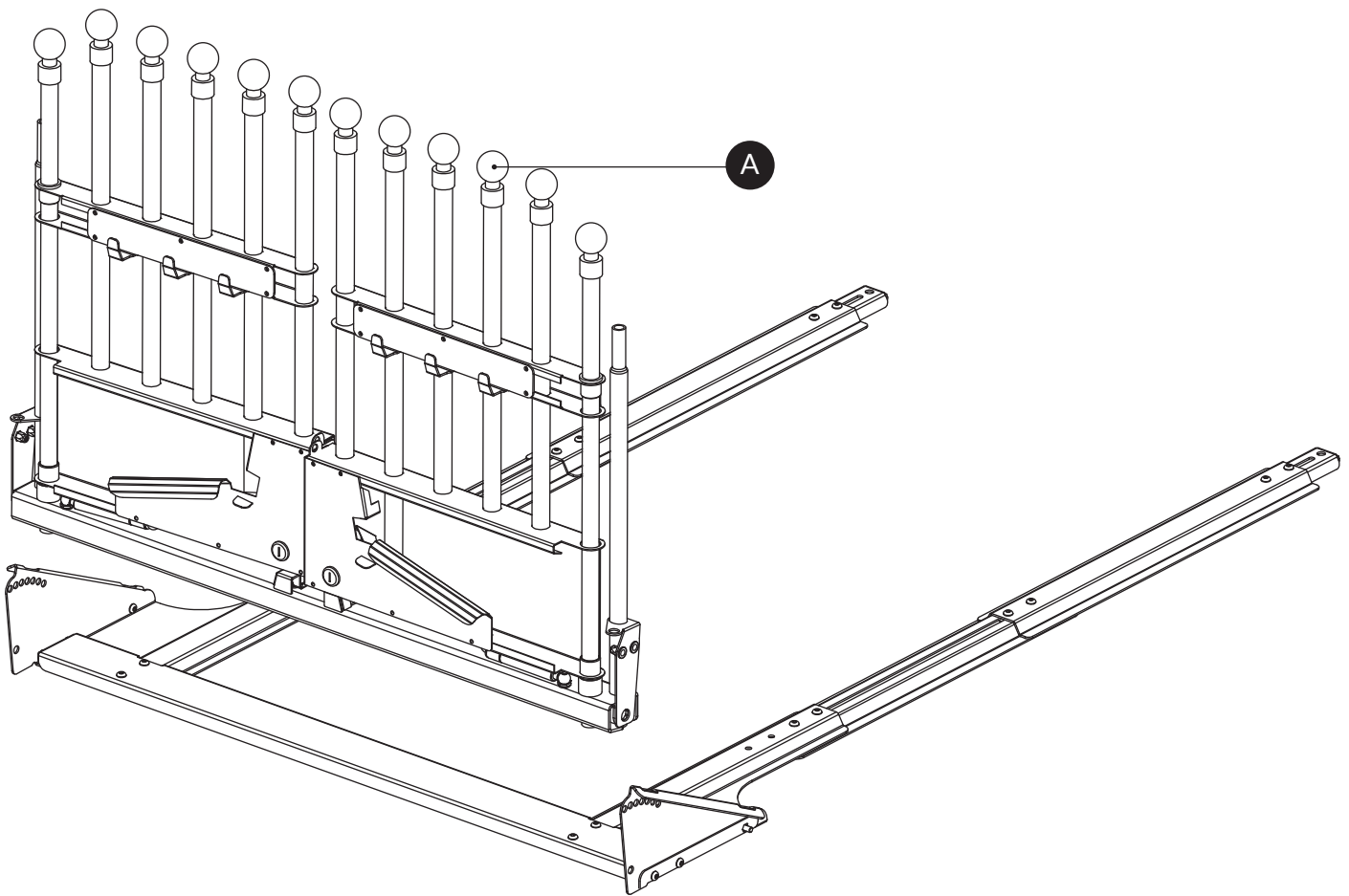

STEP
7

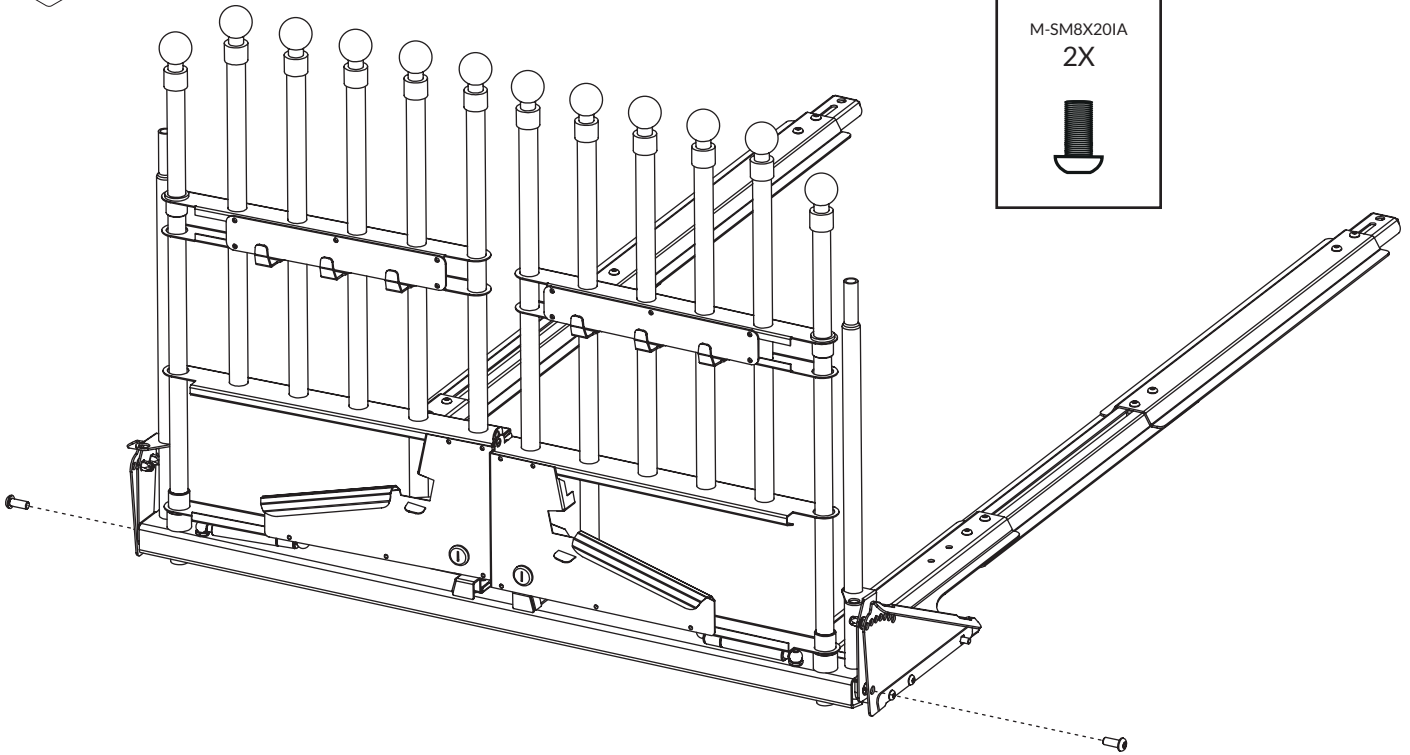

STEP
8

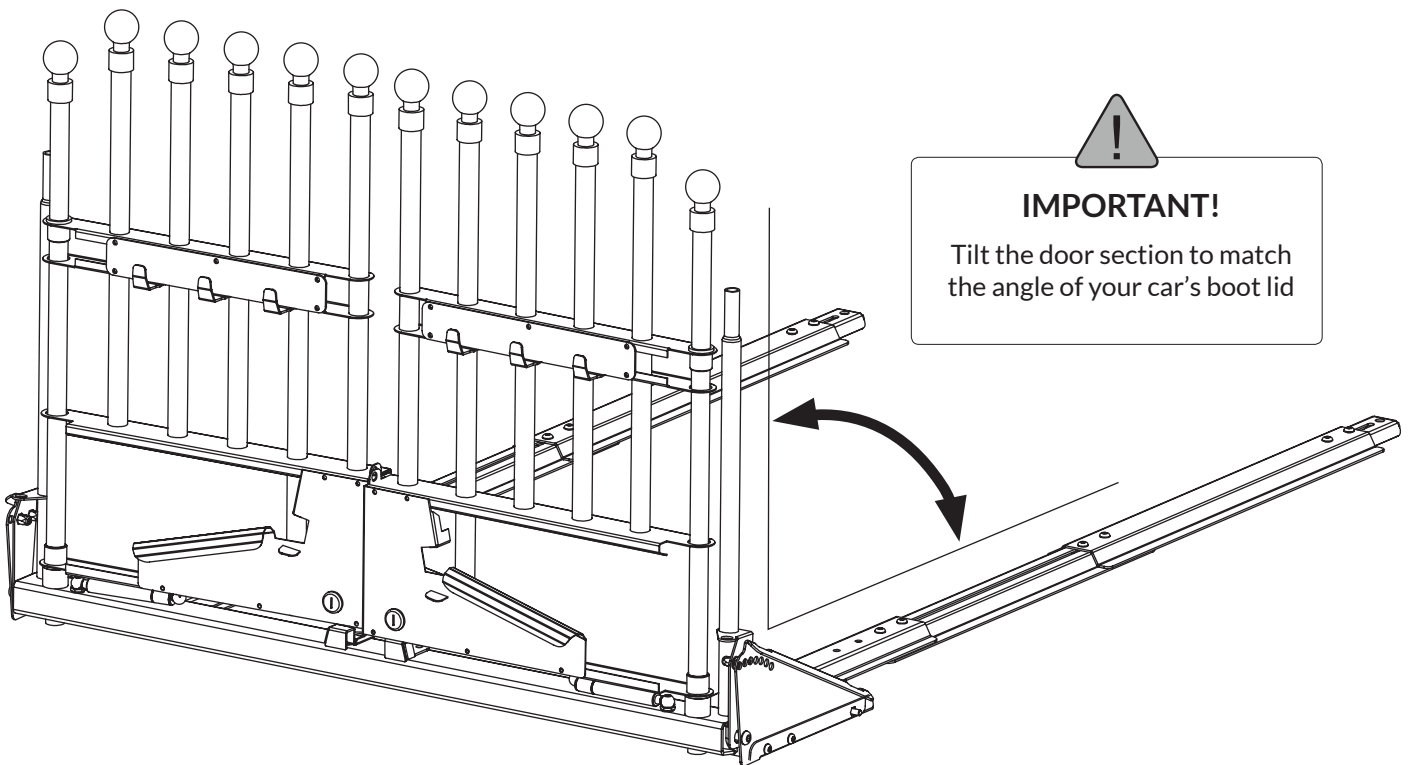

STEP
9

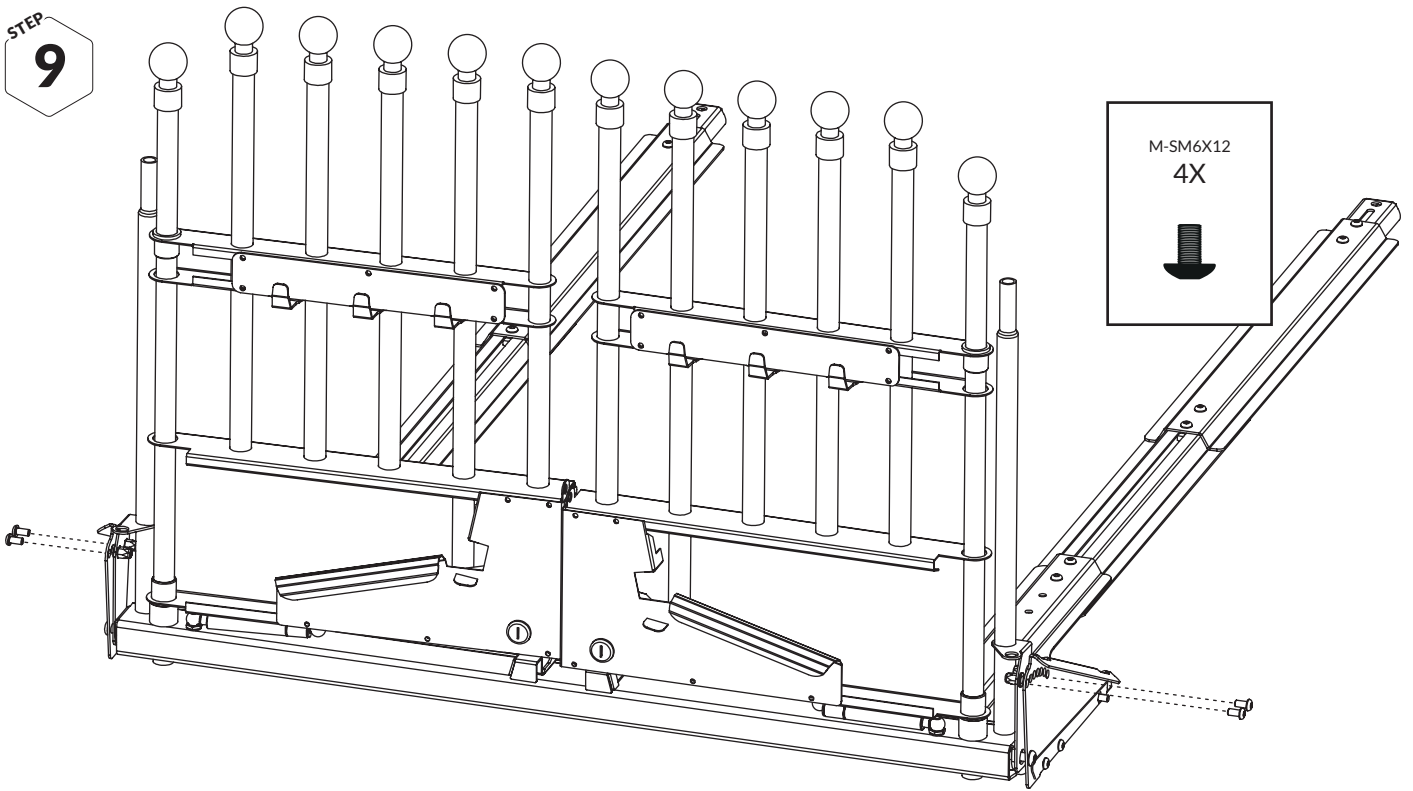

STEP
10

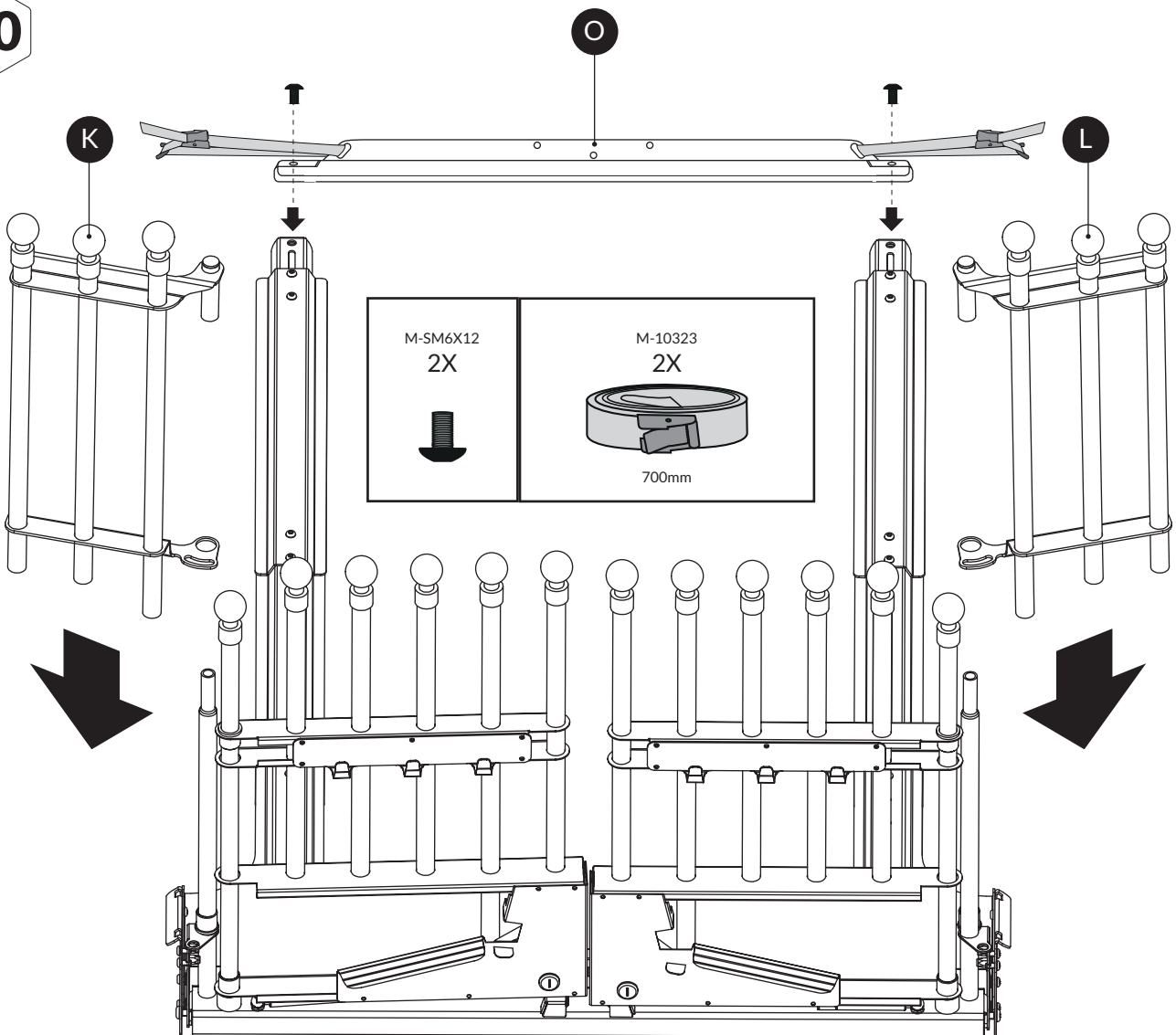

STEP
11

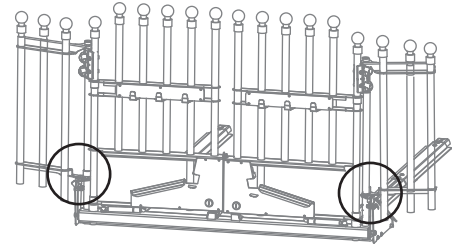

2X

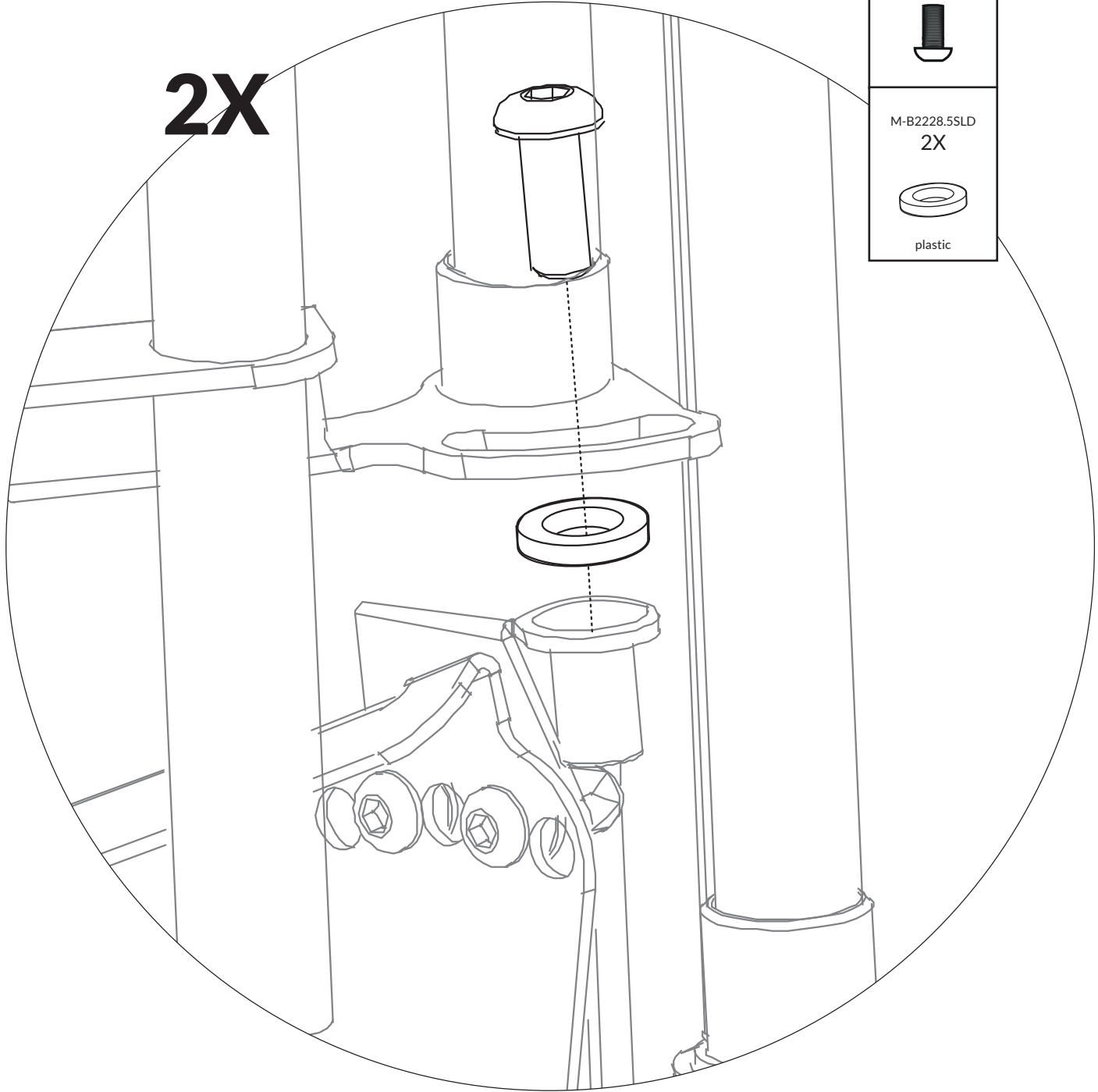

M-SM8X20IA
2X



M-B2228.5SLD
2X





plastic

STEP
12

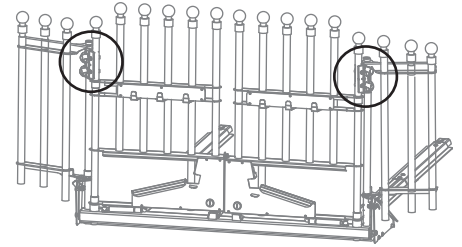
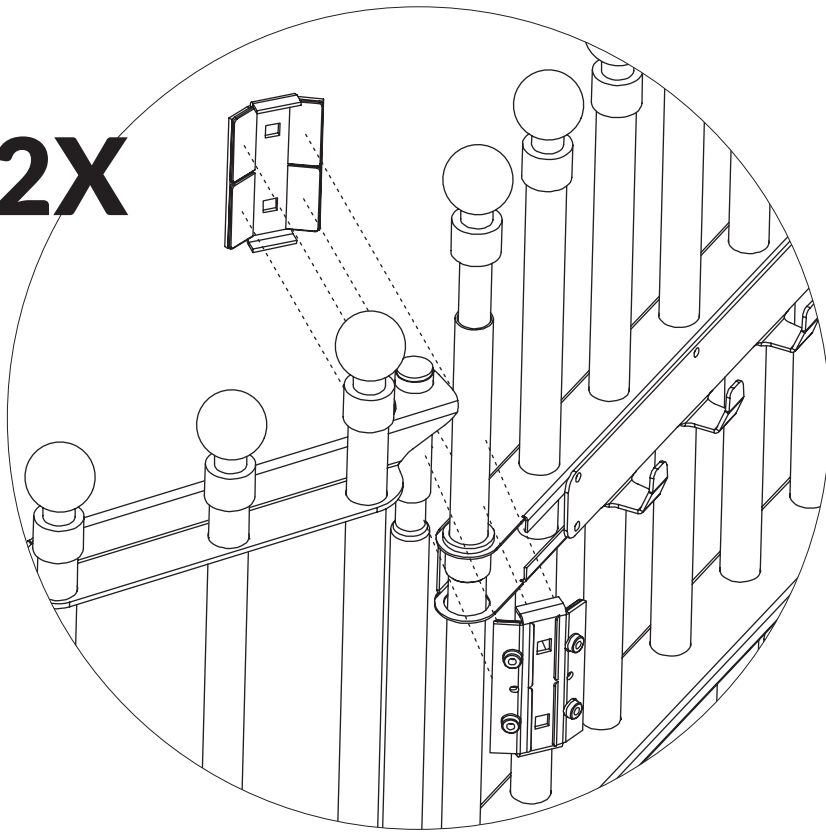
2X

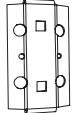



F604 4X 	M-460641D 16X  rubber
---	---

STEP
13

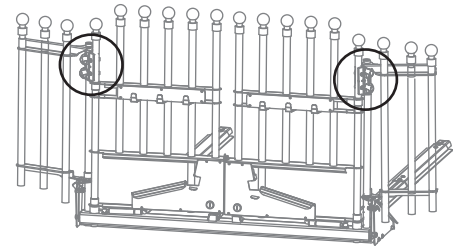
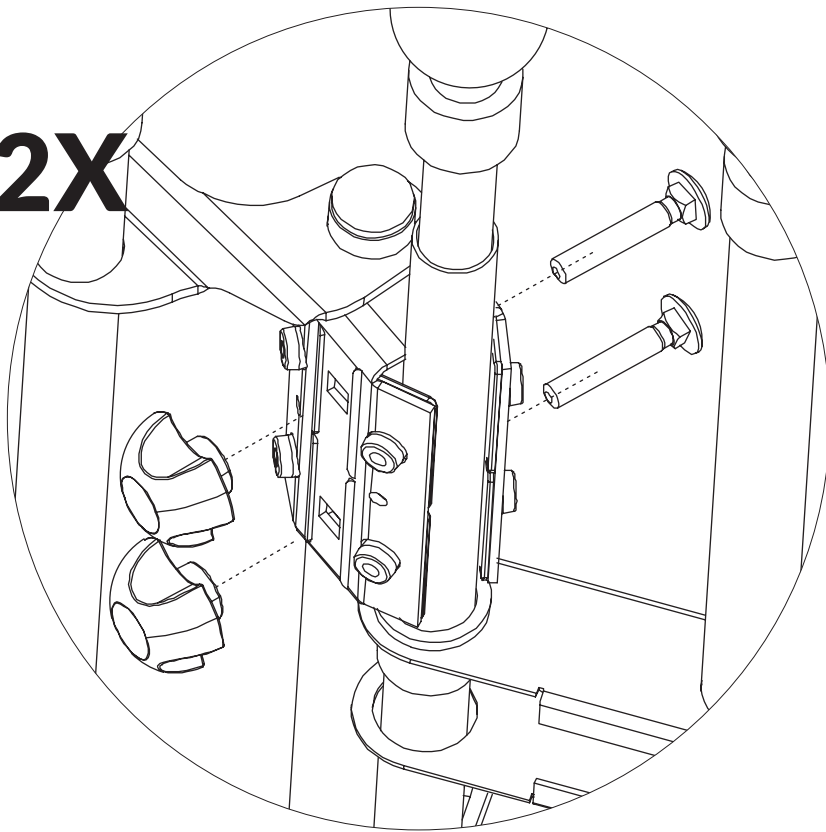
2X



M-SR3220M6S 4X 	M-VBM6X35 4X 
--	--

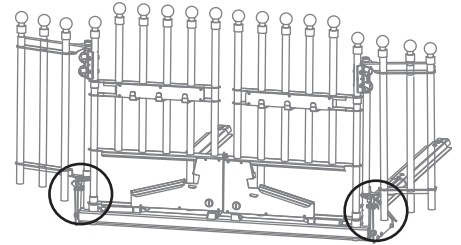
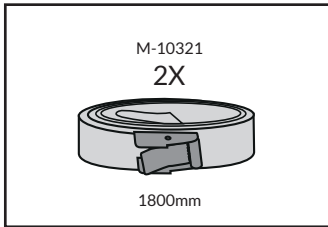

2X

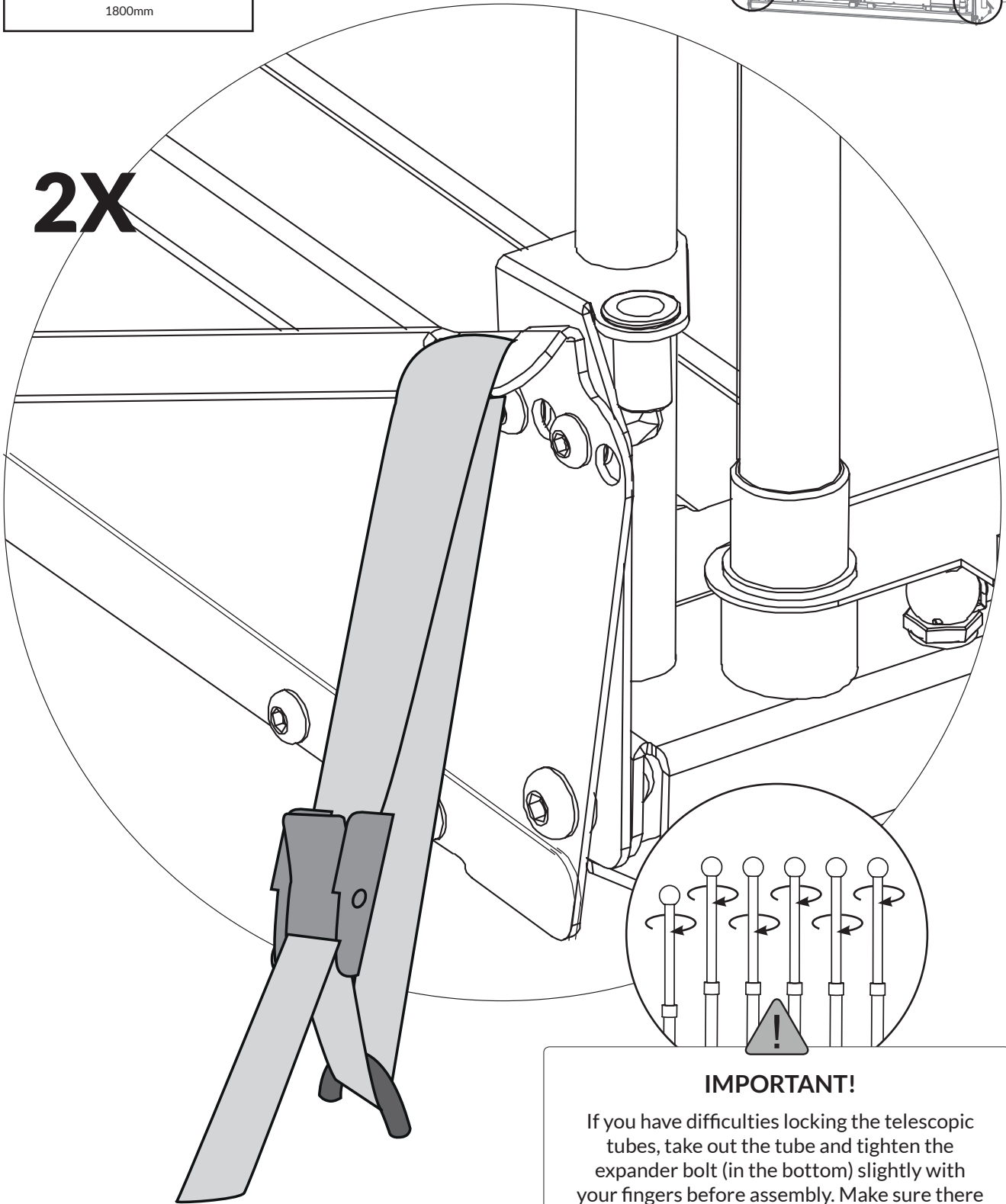

IMPORTANT!

If you have difficulties locking the telescopic tubes, take out the tube and tighten the expander bolt (in the bottom) slightly with your fingers before assembly. Make sure there is friction enough to tighten up the aluminum tube (clockwise) to avoid slide or rattling.